

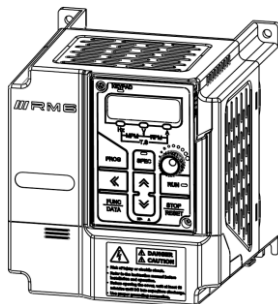

RM6G1e Series Parameter Manual



2021.11.04 Edition XB200227

Thank you for using RHYMEBUS RM6G1e series drive.
For proper operations and safety purposes, please read manual carefully.
Only the qualified personnel may proceed with the installation.
Scan the QR code on the right side for the complete operation manual.
Please pay attention to the safety precautions marked with "DANGER" or "CAUTION" in complete manual before installation.



 DANGER	User may cause the casualty or serious damages if user does not abide by the instructions of the manual to execute the tasks.
 CAUTION	User may cause injuries to the people or damage the equipment if user does not abide by the instructions of the manual to execute the tasks.

■ Standard Specifications

Single phase 200V Series

(RM6G1e-□□□□□B1)		2A005	2A007	2A010
Maximum applicable motor (HP / kW)	Heavy Duty	0.5/0.4	1/0.75	2/1.5
	Noarmal Duty	1/0.75	2/1.5	3/2.2
Rated output capacity (kVA)	Heavy Duty	1.1	1.9	3
	Noarmal Duty	1.6	2.6	3.8
Rated output current (A)	Heavy Duty	3	5	8
	Noarmal Duty	4.2	6.8	10
Maximum output voltage (V)		Three phase 200~240V (corresponding input voltage)		
Range of output freq. (Hz)		0.1~600.00Hz		
Power source (ψ, V, Hz)		Single phase 200~240V 50/60Hz		
Input current (A)	Heavy Duty	7	13.5	19
	Noarmal Duty	9.7	18.1	23.8
Permissible Ac power source fluctuation		170~264V 50/60Hz / ±5%		
Overload protection	Heavy Duty	150% of drive rated output current for 1 min		
	Noarmal Duty	120% of drive rated output current for 1 min		
Cooling method		Nature cooling		Fan cooling
Applicable safety standard		-		
Protective structure		IP20		
Weight / Mass(kg)		1.8	1.8	1.8

Three phase 200V Series

(RM6G1e-□□□□B3)		2A005	2A007	2A010	2A016	2A022
Maximum applicable motor (HP / kW)	Heavy Duty	0.5/0.4	1/0.75	2/1.5	3/2.2	5/3.7
	Noarmal Duty	1/0.75	2/1.5	3/2.2	5/3.7	7.5/5.5
Rated output capacity (kVA)	Heavy Duty	1.1	1.9	3	4.2	6.5
	Noarmal Duty	1.6	2.6	3.8	5.8	8.1
Rated output current (A)	Heavy Duty	3	5	8	11	17
	Noarmal Duty	4.2	6.8	10	15.2	21.3
Maximum output voltage (V)		Three phase 200~240V (corresponding input voltage)				
Range of output freq. (Hz)		0.1~600.00Hz				
Power source (ϕ, V, Hz)		Three phase 200~240V 50/60Hz				
Input current (A)	Heavy Duty	4	6	10	14	18
	Noarmal Duty	5	8	12	18	25.2
Permissible Ac power source fluctuation		170~264V 50/60Hz / ±5%				
Overload protection	Heavy Duty	150% of drive rated output current for 1 min				
	Noarmal Duty	120% of drive rated output current for 1 min				
Cooling method		Nature cooling		Fan cooling		
Applicable safety standard		-				
Protective structure		IP20				
Weight / Mass(kg)		1.8	1.8	1.8	2.0	2.1

Three phase 400V Series

(RM6G1e-□□□□□B3)		4A003	4A004	4A005	4A009	4A012
Maximum applicable motor (HP / kW)	Heavy Duty	0.5/0.4	1/0.75	2/1.5	3/2.2	5/3.7
	Noarmal Duty	1/0.75	2/1.5	3/2.2	5/3.7	7.5/5.5
Rated output capacity (kVA)	Heavy Duty	1.1	1.9	3	4.6	6.9
	Noarmal Duty	1.8	2.7	3.8	6.9	8.6
Rated output current (A)	Heavy Duty	1.5	2.5	4	6	9
	Noarmal Duty	2.4	3.5	5	9	11.3
Maximum output voltage (V)		Three phase 380~480V (corresponding input voltage)				
Range of output freq. (Hz)		0.1~600.00Hz				
Power source (ϕ, V, Hz)		Three phase 380~480V 50/60Hz				
Input current (A)	Heavy Duty	2	3.5	5	8	12
	Noarmal Duty	2.8	4.2	5.8	12	13.4
Permissible Ac power source fluctuation						
Overload protection	Heavy Duty	150% of drive rated output current for 1 min				
	Noarmal Duty	120% of drive rated output current for 1 min				
Cooling method		Nature cooling		Fan cooling		
Applicable safety standard		-				
Protective structure		IP20				
Weight / Mass(kg)		1.8	1.8	1.9	2.0	2.0

■ Terminal Wiring Diagram

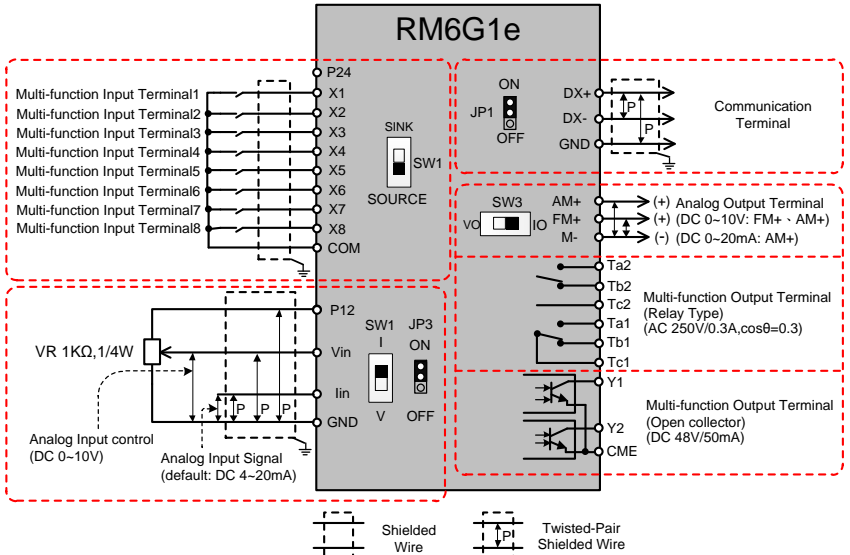

- ※1.JP1: Terminal resistor selection of communication control.
The internal resistance is 100Ω.
- ※2.JP2: Terminal resistor selection of KP-601A.
The internal resistance is 100Ω.
- ※3.JP3: Input impedance selection of lin.
ON:250Ω (Default value)
OFF:500Ω
- ※4.JP4: ON:GND and COM are short-circuited.
OFF:GND and COM are open-circuited(Default value)
- ※5.SW1: SINK / SOURCE selection;
SINK/SOURCE mode selection of X1 to X8.
- ※6.SW2: "lin" terminal input selection;
I position: Current signal (default setting)
V position: Voltage signal
- ※7.SW3:"AM+" analog output terminal jumper selection;
IO position: output current signal (default setting)
VO position: output voltage signal

■ Descriptions of Control Circuit Terminals

Type	Symbol	Function	Description
Control Power	P24	Power terminal	Output DC+24V; Maximum supplied current is 100mA
	P10	Power terminal	Output DC+10V; Maximum supplied current is 20mA
	GND	Common terminal	Common terminal for control power(P10,P24), analog input (Vin,lin), and analog output(AM+,FM+)
Input Terminal	X1	Multi-function input terminal 1~8	Set the function at H1-00 (Default: Forward)
	X2		Set the function at H1-01 (Default: Reverse)
	X3		Set the function at H1-02 (Default: Jog)
	X4		Set the function at H1-03 (Default: External fault)
	X5		Set the function at H1-04 (Default: Reset)
	X6		Set the function at H1-05 (Default: Disable)
	X7		Set the function at H1-06 (Default: Disable)
	X8		Set the function at H1-07 (Default: Disable)
	COM	Common terminal	Common of input terminal (X1~X8) and P24
	Vin	Analog input terminal	Input range: DC 0~10V. Input impedance 20kΩ. Set the function at H3-01 (Default: Freq. command)
lin	Input selection: SW2: I position. Input impedance 250Ω. SW2: V position. Input impedance 20kΩ Input range: DC 0~20mA (0~10V) or DC 4~20mA(2~10V). Set the function at H3-11 (Default: Disable)		
Output Terminal	FM+	Analog output terminal	Output voltage signal:DC0~10V Max output current:2mA Set the function at H4-00 (Default:Output Freq.)
	AM+		Output current(SW3:IO position): Output range:0~20mA or 4~20mA Max output impedance 500Ω Output Voltage(SW3:VO position): Output range:0~10VDC; Max output current: 2mA Set the function at H4-03 (Default: Output current)
	Ta1	Multi-function output terminals (relay type)	Ta1:N.O (contact a); Tb1: N.C (contact b)
	Tb1		Set the function at H2-04 (Default: Error detection)
	Tc1		Capacity: AC250V, 0.5A Max, cosθ=0.3
	Ta2		Ta2:N.O (contact a); Tb2: N.C (contact b)
	Tb2	Set the function at H2-05; Default: Detection during operation	
	Tc2	Capacity: AC250V, 0.5A Max, cosθ=0.3	
Y1	Multi-function output terminals (open collector type)	The function is set by H2-00 and H2-01.	
Y2		Capacity: DC48V, 50mAMax	
CME		Common terminal of Y1, Y2.	
Comm. Terminal	DX+	MODBUS Communication terminal	Connect the drive by transmission cable, when the drive is controlled by RS-485 communication interface. Communication protocol: Modbus(interface: RS-485)
	DX-		Terminal resistor switch is selected by JP1. Terminal resistor = 100Ω

■Digital Type Keypad KP-601A (Optional)

- 
- 1. ON: Primary frequency command is set by keypad or UP/DOWN terminal
 - 2. OFF: Primary frequency command is set by multi-function input terminals
 - 1. Enter function setting mode
 - 2. Back to monitor mode
 - Multi-function command signal
 - Move the cursor
 - 1. Enter parameter setting mode
 - 2. Back to function setting mode
 - 3. Switch monitor mode
 - Display panel
 - Unit indicator
 - Pot knob
 - Blinking: Under accel. or decel.
ON: Constant speed
OFF: Stop
 - Drive start key
 - Up/down key of changing functions and parameters
 - 1. Drive stops (cut off output frequency of drive)
 - 2. Fault reset

■Operation of Keypad

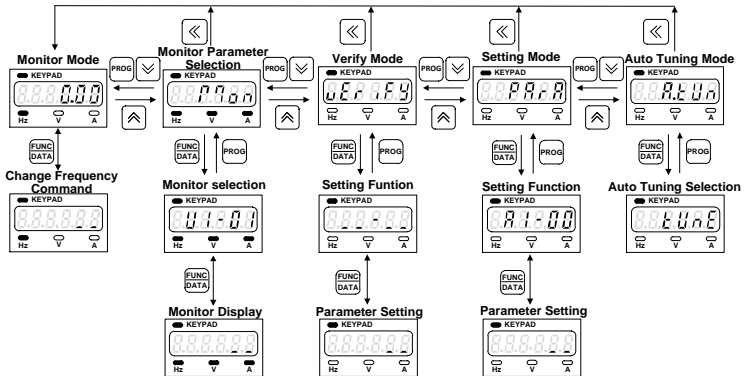

■Description of Monitor Mode

There are nine displays can be selected in the monitor mode.

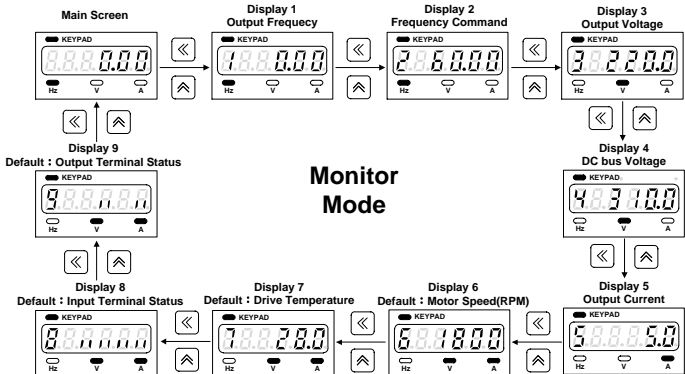

■ PM Motor Setting Step

- A. Restore the default value of PM motor (A1-05=dF_PM)
- B. Set the maximum freq. (E1-00), maximum voltage (E1-01), base freq. (E1-02), and base voltage (E1-03).
- C. Set the motor rated current (E2-01) and the number of motor poles (E2-04)
- D. Select the mode of initial position (C7-03): DC braking(C7-03=0), HFI(C7-03=1), and pulse(C7-03=4)
- E. Select the auto tuning mode (A1-03): rotational tuning (A1-03=4) or stationary tuning (A1-03=6)
 - i. Motor related parameters will update after complete tuning: line-to-line resistor (E2-05), Ld (E2-11), Lq (E2-12), and back EMF constant (E2-13)
 - ii. Please confirm the motor rotate normally when use rotational tuning.
- F. If back EMF constant is lower than 25, please try to increase the switching freq. (C7-01) and current level in IF mode (C7-00).

■ Parameter List

Group	Name	Group	Name
A1	Initialization (4000H)	E4	Motor2 Parameters (4460H)
A3	Keypad Selection (4040H)	F1	PG card setting (4600H)
A4	Function Selection (4065H)	H1	Multi-Function Digital Inputs (4A00H)
A5	Maintenance Selection (4080H)	H2	Multi-Function Digital Outputs (4A20H)
b1	Operation Mode Selection (4100H)	H3	Multi-Function Analog Inputs (4A40H)
b2	DC Braking (4120H)	H4	Multi-Function Analog Outputs (4A60H)
b3	Speed trace (4130H)	H5	ModbusSerial Communication (4A80H)
b4	Multi-Function Component (4140H)	L1	Driver & Motor Protection (4C00H)
b5	PID Control (4160H)	L2	Restart After Instant Power Failure (4C20H)
b6	Holding Function (41A0H)	L3	Stall Prevention (4C40H)
C1	Accel./Decel. Times (4200H)	L4	Speed and Torque Detection (4C60H)
C2	S-Curve Characteristics (4220H)	L5	Fault Restart (4C80H)
C3	V/F Control Compensation (4240H)	L6	Extend Protection (4CA0H)
C4	Carrier Freq. (4260H)	L7	Torque Limit (4CC0H)
C5	Automatic Speed Regulator (4280H)	P1	Sequence Control (5000H)
C7	PM Control Setting(42A0H)	P2	Traverse Function (5080H)
d1	Preset Speed (4300H)	o1	Current Loop Gain Setting (5900H)
d2	Freq. Upper/Lower Limits (4320H)	U1	Operation Status Monitor (6000H)
d3	Jump Freq. (4340H)	U2	Fault Trace (6100H)
d4	Up/Down Control (4360H)	U3	Fault History (6200H)
d5	Torque Control (4380H)	U4	Maintenance Monitor (6300H)
d6	Field Weakening (43A0H)	U5	PID Monitor (6400H)
d7	Offset Freq. (43B0H)	U6	Operation Status Monitor 2 (6500H)
E1	Motor1 V/F Pattern (4400H)	U7	Program Control Monitor (6600H)
E2	Motor1 Parameters (4420H)	U8	System Monitor (6700H)
E3	Motor2 V/F Pattern (4440H)		

 means function can be set up during the operation.

Setting Parameters List

Func.	Name	Range	dF60
A1-02	Control Method Selection	0:V/F Control 2:Vector Control 6:PM Control 1 (I/F+EMF) 7:PM Control 2 (HF+EMF)	0
A1-03	Auto tuning Function	0:Disable 2:Stationary tuning with no-load current 4:Rotational tuning(PM motor) 6:Stationary tuning (PM motor)	0
A1-04	Power Source	190.0~240.0V(220V series) 340.0~480.0V(380V series)	220.0 380.0
A1-05	Default Setting	none dF60:Default value for 60Hz dF50:Default value for 50Hz dFPFM:PM motor default value dFSol:solar pump mode dFPid:PID function mode dF_nD:normal duty mode dF_HD:heavy duty mode SAV:Save the setting value rES:Restore the setting value Wr_KP: Keypad ← Drive rd_KP: Keypad → Drive CommT:Communication test	—
A1-06	Proportion of Output Voltage for Auto tuning	0~15	8
A1-07	Parameter Password Input/ Recode	0000~9999	—
A1-08	Parameter Password Setting	0000~9999	—
A1-09	Display selection of Parameter Lock	0:Only display A1-07 1:Display all functions	0
A1-11	Simple parameter Lock	0:Disable 1:Enable,only can adjust A3-00, A3-20~A3-22, and B5-17	0
A3-00	Keypad Freq. Command	0.00~E1-00 Hz	60.00
A3-01	Keypad Freq. Selection	0:A3-00 (Digital) 1:Pot knob(Analog)	0
A3-02	Keypad Pot Function Selection	0~19(Please refer to H3-01) Enable when A3-01=0	0
A3-03	Keypad Pot Response	0.000~50.00 sec	0.000
A3-04	Function Selection (SPEC)	-62~+62 (Please refer to H1-00)	0
A3-05	Self-holding (SPEC)	0:Disable 1:Enable	0
A3-06	Main Display Selection	000~999	102
A3-07	Display 6	000~999	109
A3-08	Display 7	000~999	106
A3-09	Display 8	000~999	107
A3-10	Display 9	000~999	108
A3-11	Main Display Gain 1	0.01~100.00	1.00
A3-12	Main Display Gain 2	0.1~1000.0	1.0
A3-13	Main Display Decimal Value	0~3	3

Func.	Name	Range	dF60
A3-14	Validity range of STOP (keypad)	0:All range 1:b1-00=2	0
A3-15	Freq. Command Selection (keypad)	0:Command is changeable in the monitor mode 1:Command is fixed in the monitor mode	0
A3-16	Display and "—" show alternately at Stop	0:Disable 1:Enable 2:b1-02=1	2
A3-17	Parameter Setting Method	0:Effective when press key 1:Effective when setting is changed	0
A3-18	Selection When Keypad is Disconnected	0:Drive keeps operation 1:Drive trips "PADF"	0
A3-19	Function of "Func/Data" Key	0:A3-00 3:A3-22 1:A3-20 4:B5-17 2:A3-21	0
A3-20	MPM Command 0	0~(E1-00)*(b1-15)*(b1-16)	50
A3-21	MPM Command 1	0~(E1-00)*(b1-15)*(b1-16)	50
A3-22	MPM Command 2	0~(E1-00)*(b1-15)*(b1-16)	50
A3-23	Dual Display	000~999	000
A3-24	Main Display in Secondary Freq.	000~999	102
A3-25	Secondary Display in Secondary Freq.	000~999	000
A4-00	Control Function Selection	0:None 2:Reserve 1:Reserve 3:Reserve	0
A5-00	U2-00 Setting	0~9	0
A5-01	Maintenance Management Function	0:None 1:Clr.Err :Clear Fault records 2:Clr.kwh: Clear Watt-hour meter 3:Clr.All :Clear all item	—
A5-02	Cumulative Power On Setting	0~49999 hr	0
A5-03	Cumulative Operation Time Setting	0~49999 hr	0
A5-04	Cooling Fan Operation Time Setting	0~49999 hr	0
b1-00	Primary Freq. Selection	0.Keypad 1.Digital Input (X1~X8) 2.Analog Input (AI) 3.Communication	0
b1-01	Secondary Freq. Selection	7.MPM speed 0 8.MPM speed 1 9.MPM speed 2 10.PID output	0
b1-02	Primary Start Command	0:Keypad() key 1:Digital input(X1~X8)	0
b1-03	Secondary Start Command	2:Communication interface	0
b1-04	Primary Direction Command	0:Keypad() key + A3-04=5)	0
b1-05	Secondary Direction Command	1:Digital input(X1~X8) 2:Communication interface	0
b1-07	Number of Digital Input Terminal controls by Modbus	0~8	8
b1-10	Stop method	0:Ramp to Stop + DC braking 1:Coast to stop 2:Coast to stop + DC braking	0

Func.	Name	Range	dF60
b1-11	Reverse Operation Selection	0:Enable 1:Disable	0
b1-12	Phase Order Selection	0:Clockwise (IEC) 1:Counterclockwise (NEMA)	0
b1-13	Operation Selection after Local/Remote Switching	0:Cut off the start command and issue the new start command to operate 1:Operate immediately if the start command issue	0
b1-14	Run Selection at Power ON	0:Cut off the start command and issue the new start command to operate 1:Operate immediately if the start command issue	0
b1-15	MPM gain 1	MPM	1
b1-16	MPM gain 2	$\text{Freq.} = \frac{\text{MPM}}{b1-15 \times b1-16}$	1
b2-00	DC Braking Freq.	0.1~60.0Hz	0.5
b2-01	DC Braking Level	0~150% of drive rated current	50
b2-02	DC Braking Response Time	0.001~60.000 sec	1.000
b2-03	Time of DC Braking at Start	0.0~60.0 sec	0.0
b2-04	Time of DC Braking after Ramp to Stop	0.0~60.0 sec	0.5
b2-05	Delay Time of DC Braking after Coast to Stop	0.0~60.0 sec	0.5
b2-06	Time of DC Braking after Coast to Stop	0.0~600.0 sec	5.0
b2-07	DC Braking Level at Zero Speed	0~150% of drive rated current	0
b3-00	Speed Trace Selection at Start	0:None 1:Setting freq. 2:Maximum freq.	0
b3-01	Current Level of Speed Trace	0~200% of drive rated current	150
b3-02	V/F Gain During Speed Trace	0.10~1.00	1.00
b3-03	Wait / Trace Time of Speed Trace	0.0~100.0sec	0.5
b3-04	Acceleration Time of Speed Trace	0.1~6.0sec	0.4
b3-05	Deceleration Time of Speed Trace	0.1~10.0sec	2.0
b3-06	Stable Time of Speed Trace	0~500ms	200
b3-07	Start Freq. Gain During Speed Trace	0.10~1.00	1.00
b3-08	Filter Constant of Speed Trace	0.001~1.000	0.03
b4-00	Counter Mode	0:Up counter mode 1:Down counter mode	0
b4-01	Counter Value 1	0~60000	0
b4-02	Counter Value 2	0~60000	0
b4-03	Counter Cycle Value	0~60000	0

Func.	Name	Range	dF60
b4-04	Timer ON-Delay Time	0.0~6000.0 sec	0.0
b4-05	Timer OFF-Delay Time	0.0~6000.0 sec	0.0
b5-00	PID Function Selection	0:PID OFF 1:Freq. Output =PID 2:Freq. Output =PID + Freq. command 3:External usage(working when power is on) 4:External usage(working when operating) 5:External usage(working depend on X1~X6)	0
b5-01	Proportional Gain 1(P)	0.00~100.00	1.00
b5-02	Integration Time 1(I)	0.000~36.000 sec	1.000
b5-03	Derivative Time1(D)	0.000~10.000 sec	0.000
b5-04	Proportional Gain 2(P)	0.00~100.00	1.00
b5-05	Integral Time 2(I)	0.000~36.000 sec	1.000
b5-06	Derivative Time2(D)	0.000~10.000 sec	0.000
b5-07	Integral Upper Limit	-1.00~1.00	1.00
b5-08	Integral Lower Limit	-1.00~1.00	0.00
b5-09	Integral Initial Value	-320.00~320.00	0.00
b5-10	PID Input Limit	0.00~1.00	1.00
b5-11	PID Delay Time	0.00~10.00 sec	0.00
b5-12	PID Output Bias	-1.00~1.00	0.00
b5-13	PID Output Gain	-25.00~25.00	1.00
b5-14	PID Proportional Selection	0: General mode 1: prepositive mode	0
b5-15	PID Derivative Selection	0: General mode 1: prepositive mode	0
b5-16	PID Feedback Filter	0.001~1.000	1.000
b5-17	PID Set Point Value	-320.00~320.00	0.00
b5-18	Feedforward Controller Gain	-25.00~25.00	0.00
b5-19	Feedforward Controller Limit	-1.00~1.00	0.00
b5-20	PID Output Limit	0.00~1.00	0.00
b5-21	PID Output 2 Upper Limit	-1.00~1.00	1.00
b5-22	PID Output 2 Lower Limit	-1.00~1.00	0.00
b5-23	PID Feedback loss Detection Selection	0: None 1: Alarm 2: Ramp to stop 3: Coast to stop	0
b5-24	PID Feedback Low Detection Level	-1.00~1.00	-1.00
b5-25	PID Feedback Low Detection Time	0.0~60.0 sec	1.0
b5-26	PID Feedback High Detection Level	-1.00~1.00	1.00
b5-27	PID Feedback High Detection Time	0.0~60.0 sec	1.0

Func.	Name	Range	dF60
b5-28	PID Sleep Initial Freq.	-320.00~320.00	0.00
b5-29	PID Sleep Delay Time	0.0~600.0 sec	0.0
b5-30	PID Wakeup Initial Freq.	-320.00~320.00	0.00
b5-31	PID Wakeup Delay Time	0.0~600.0 sec	0.0
b5-32	PID Error Dead Band	0.000~1.000	0.001
b5-33	Holding Time of PID Parameter Switching	0.000~60.000 sec	0.000
b5-34	PID Softer Start Accel./Decel. Time	0.0~6000.0 sec	0.0
b5-35	PID Direction Selection	0: Forward control 1: Reverse control	0
b5-36	Upper Limit of Transmitter	-320.00~320.00	1.00
b5-37	Lower Limit of Transmitter	-320.00~320.00	0.00
b5-38	2nd PI control selection	0: Depend on b5-40 1: Switch back to the primary PI after the deviation is lower than 5% of b5-39.	0
b5-39	(2nd PI) Active Range	-320.00~320.00	1.00
b5-40	(2nd PI) Active Time	0.0~300.0 sec	0.0
b6-00	Holding Freq. at Start	0.00~600.00 Hz	0.00
b6-01	Holding Time at Start	0.0~360.0 sec	0.0
b6-02	Holding Freq. at Stop	0.00~600.00 Hz	0.00
b6-03	Holding Time at Stop	0.0~360.0 sec	0.0
C1-00	Reference Freq. of Accel./Decel. Time	0.01~600.00 Hz	60.00
C1-01	Accel. Time 0	0.0~3200.0 sec	5.0
C1-02	Decel. Time 0	0.0~3200.0 sec	5.0
C1-03	Accel. Time 1	0.0~3200.0 sec	5.0
C1-04	Decel. Time 1	0.0~3200.0 sec	5.0
C1-05	Accel. Time 2 (Motor 2 Accel. Time 0)	0.0~3200.0 sec	5.0
C1-06	Decel. Time 2 (Motor 2 Dccel. Time 0)	0.0~3200.0 sec	5.0
C1-07	Accel. Time 3 (Motor 2 Accel. Time 1)	0.0~3200.0 sec	5.0
C1-08	Decel. Time 3 (Motor 2 Dccel. Time 1)	0.0~3200.0 sec	5.0
C1-09	Secondary Accel. Time	0.0~3200.0 sec	5.0
C1-10	Secondary Decel. Time	0.0~3200.0 sec	5.0
C1-11	Accel. Time When Output Voltage Adjustment of V/F Pattern	0.0~3200.0 sec	5.0
C1-12	Decel. Time When Output Voltage Adjustment of V/F Pattern	0.0~3200.0 sec	5.0
C1-13	Fast Stop Time	0.0~3200.0 sec	5.0
C1-14	Accel./Decel. Time Unit	0:0.1~3200 sec 1:0.01~320 sec	0

Func.	Name	Range	dF60
C1-15	Accel./Decel. Time Switching Freq.	0~400 Hz	0
C2-00	S-Curve time at Accel Start	0.00~10.00 sec	0.00
C2-01	S-Curve time at Accel End	0.00~10.00 sec	0.00
C2-02	S-Curve time at Decel Start	0.00~10.00 sec	0.00
C2-03	S-Curve time at Decel End	0.00~10.00 sec	0.00
C3-00	Motor Slip Compensation	-60.0~60.0 Hz	0.0
C3-01	Slip Compensation Response Time	0.000~10.000 sec	0.800
C3-02	Automatic Voltage Regulation (AVR)	0:Disable 1:Enable at all range 2:Disable at decel.(V/F) / Enable at decel.(OLV)	1
C3-03	Response Time of AVR	0.000~20.000 sec	0.050
C3-04	Current Oscillation Compensation Gain	0.0~500.0	1.0
C3-05	Current Oscillation Compensation Response Time	0~1.000 sec	0.000
C3-06	Automatic Torque Compensation Gain	0~25.5	1.0
C3-07	Automatic Torque Compensation Response Time	0~20.000 sec	1.000
C3-08	Low Speed Slip Compensation Gain	0~100	0
C3-10	Motor 2 Slip Compensation	-60.0~60.0 Hz	0.0
C3-11	Motor 2 Slip Compensation Response Time	0.000~10.000 sec	0.800
C3-12	Motor 2 Automatic Voltage Regulation (AVR)	0:Disable 1:Enable at all range 2:Disable at decel.(V/F) / Enable at decel.(OLV)	1
C3-13	Motor 2 Response Time of AVR	0.000~20.000 sec	1.000
C3-14	Motor 2 Current Oscillation Compensation Gain	0.0~500.0	1.0
C3-15	Motor 2 Current Oscillation Compensation Response Time	0~1.000 sec	0.010
C3-16	Motor 2 Automatic Torque Compensation Gain	0~25.5	1.0
C3-17	Motor 2 Automatic Torque Compensation Response Time	0~20.000 sec	1.000
C3-18	Motor 2 Low Speed Slip Compensation Gain	0~100	0
C3-20	Motor 1 Current Oscillation Compensation Gain	0.0~300.0	0.0

Func.	Name	Range	dF60
C3-21	Motor 1 Current Oscillation Compensation Filter	0.00~1.000	0.100
C3-22	Motor 2 Current Oscillation Compensation Gain	0.0~300.0	0.0
C3-23	Motor 2 Current Oscillation Compensation Filter	0.000~1.000	0.100
C4-00	Carrier Freq.	0~6	1
C5-00	ASR Proportional Gain 1(P)	0.00~300.00	2.00
C5-01	ASR Integral Time 1(I)	0.000~10.000 sec	0.05
C5-02	ASR Proportional Gain 2(P)	0.00~300.00	4.00
C5-03	ASR Integral Time 2(I)	0.000~10.000 sec	0.050
C5-06	ASR Delay Time	0.000~0.500 sec	0.200
C5-07	ASR Switching Freq.	0.0~400.0Hz	120.0
C5-08	ASR Integral Limit	0~400%	400
C5-09	Speed Estimator Proportional Gain	0.00~10.00	0.25
C5-10	Speed Estimator Integral Gain	0.0~200.0	25.0
C5-11	EMF Proportional Gain For High speed	0.01~100.00	1.60
C5-12	EMF Proportional Gain For Low speed	0.01~100.00	0.8
C5-13	EMF Compensation Proportional Gain	0.00~100.00	1.00
C5-14	EMF Compensation Integral Gain	0.00~100.00	16.00
C7-00	Current Level in IF mode	0.00~1.00	0.00
C7-01	PM Control Method Switching Freq.	0.0~100.0Hz	20.0
C7-02	HFI Signal Low Pass Filter	0.000~1.000	0.000
C7-03	HFI Control Method	0:DC braking positioning 1:HFI positioning 2:Pulse positioning	0
C7-04	Timeout of HFI Initial Position Detection	0.00~5.00 sec	0.50
C7-05	HFI Angle Offset	-1.00~1.00	0.10
C7-06	HFI Freq.	0~2000 Hz	800
C7-07	HFI Voltage	0.00~0.50	0.20
C7-08	Judgment Level of HFI Success	-1.00~1.00	0.00
C7-10	Current Offset Of d-axis	-0.50~0.50	0.00
C7-11	Gain of Voltage Utilization	0~10	0
C7-12	Duty of Pulse Positioning	1~1000	150
d1-00	Preset Speed 0	0.00~600.00	60.00
d1-01	Preset Speed 1	0.00~600.00	10.00
d1-02	Preset Speed 2	0.00~600.00	20.00
d1-03	Preset Speed 3	0.00~600.00	30.00
d1-04	Preset Speed 4	0.00~600.00	0.00
d1-05	Preset Speed 5	0.00~600.00	0.00
d1-06	Preset Speed 6	0.00~600.00	0.00

Func.	Name	Range	dF60
d1-06	Preset Speed 6	0.00~600.00	0.00
d1-07	Preset Speed 7	0.00~600.00	0.00
d1-08	Preset Speed 8	0.00~600.00	0.00
d1-09	Preset Speed 9	0.00~600.00	0.00
d1-10	Preset Speed 10	0.00~600.00	0.00
d1-11	Preset Speed 11	0.00~600.00	0.00
d1-12	Preset Speed 12	0.00~600.00	0.00
d1-13	Preset Speed 13	0.00~600.00	0.00
d1-14	Preset Speed 14	0.00~600.00	0.00
d1-15	Preset Speed 15	0.00~600.00	0.00
d1-16	Jog Speed	0.00~600.00	6.00
d2-00	Output Freq. Limit Selection	0:d2-01 and d2-02 1:d2-03 and d2-04	0
d2-01	Freq. Upper Limit (%)	0.00~1.00	1.00
d2-02	Freq. Lower Limit (%)	0.00~1.00	0.00
d2-03	Freq. Upper Limit (Hz)	0.00~600.00Hz	60.00
d2-04	Freq. Lower Limit (Hz)	0.00~600.00Hz	0.00
d3-00	Jump Freq. 1	0.1~600.0Hz	0.0
d3-01	Jump Freq. 2	0.1~600.0Hz	0.0
d3-02	Jump Freq. 3	0.1~600.0Hz	0.0
d3-03	Jump Freq. Range	0.1~20.0Hz	1.0
d4-00	UP/DOWN Memory Selection	0:Disable 1:Enable	0
d4-01	UP/DOWN Freq. Resolution	0.01~25.00Hz	0.01
d4-02	UP/DOWN Trigger Mode	0:Edge trigger 1~5:Response time(sec)	0
d4-03	UP/DOWN Freq. Adjustment	0.00~600.00Hz	0.00
d4-04	Freq. Resolution during Accel./Decel.	0.01~25.00Hz	4.00
d5-01	Torque Control Selection	0:Speed Control 1:Torque Control	0
d5-02	Torque Command Delay Time	0~1000 msec	0
d5-03	Speed Limit Selection	0:Freq. command 1:d5-04	0
d5-05	Speed Limit Bias	0~120%	10
d5-06	Speed/Torque Control Switch Delay Time	0~1000 msec	0
d5-08	Unidirectional Speed Limit bias	0:Disabled (bidirectional) 1:Enabled (unidirectional)	1
d5-10	T/F Curve Max Torque Gain	0~2.000	1.000
d5-11	T/F Curve Max Freq.	0~600.0	60.0
d5-12	T/F Curve Mini Torque Gain	0~2.000	1.000
d5-13	T/F Curve Mini Freq.	0~600.0	0.0
d6-00	Field Weakening Level	0~100%	80%
d6-01	Field Weakening Freq. Limit	0~400Hz	0.0
d7-00	Offset Freq. 0	-1.00~1.00	0.00
d7-01	Offset Freq. 1	-1.00~1.00	0.00
d7-02	Offset Freq. 2	-1.00~1.00	0.00
E1-00	Maximum Output Freq.	0.1~600.0Hz	60.0
E1-01	Maximum Output Voltage	0.0~255.0V (220V series) 0.0~510.0V (380V series)	220.0 380.0
E1-02	Base Freq.	0.1~600.0Hz	60.0
E1-03	Base Voltage	0.0~255.0V (220V series) 0.0~510.0V (380V series)	220.0 380.0
E1-04	Start Freq.	0.1~10.0Hz	0.5
E1-05	Start Voltage	0.1~50.0V (220V series) 0.1~100.0V (380V series)	8.0 12.0
E1-06	V/F Freq. 1	0.1~600.0 Hz	0.0
E1-07	V/F Voltage 1	0.0~255.0V (220V series) 0.0~510.0V (380V series)	0

Func.	Name	Range	dF60
E1-08	V/F Freq. 2	0.1~600.0 Hz	0.0
E1-09	V/F Voltage 2	0.0~255.0V (220V series) 0.0~510.0V (380V series)	0
E1-10	Output Voltage Limit	0:Disable 1:Enable	0
E1-11	VF Pattern	0:Linear 1:Energy-saving 2:Square Curve 3:1.7 th power Curve 4:1.5 th power Curve	0
E1-12	Non-linear Start Freq.	0.1~600.0 Hz	0.0
E1-13	Non-Linear Start Voltage	0.0~255.0V (220V series) 0.0~510.0V (380V series)	0.0
E1-14	Voltage Boost Ratio at Acceleration	0~100	0
E1-15	Voltage Buck Time after Boost Voltage	1.0~60.0 msec	10.0
E2-01	Motor Rated Current	10~150% of drive rated current	—
E2-02	Motor Rated Slip	0.00~20.00 Hz	—
E2-03	Motor No-Load Current	0~E2-01	—
E2-04	Motor Poles	1~24	4
E2-05	Motor Line-to-Line Resistance	0.001~65.000 Ω	—
E2-06	Motor Leakage Inductance	0.01~40.0 %	—
E2-07	Motor Iron-Core Saturation Coefficient 1	0.01~1.00	0.9
E2-08	Motor Iron-Core Saturation Coefficient 2	0.01~1.00	0.8
E2-09	Motor Iron-Core Saturation Coefficient 3	0.01~1.00	0.7
E2-11	PM Motor Ld	0.001~60.000 mH	3.000
E2-12	PM Motor Lq	0.001~60.000 mH	3.000
E2-13	Back-EMF Constant	0.0~6500.0	60.0
E3-00	Motor 2 Maximum Output Freq.	0.1~600.0 Hz	60.0
E3-01	Motor 2 Maximum Output Voltage	0.0~255.0V (220V series) 0.0~510.0V (380V series)	220.0 380.0
E3-02	Motor 2 Base Freq.	0.1~600.0Hz	60.0
E3-03	Motor 2 Base Voltage	0.0~255.0V (220V series) 0.0~510.0V (380V series)	220.0 380.0
E3-04	Motor 2 Start Freq.	0.1~10.0 Hz	0.5
E3-05	Motor 2 Start Voltage	0.1~50.0V (220V series) 0.1~100.0V (380V series)	8.0 12.0
E3-06	Motor 2 V/F Freq. 1	0.1~600.0 Hz	0.0
E3-07	Motor 2 V/F Voltage 1	0.0~255.0V (220V series) 0.0~510.0V (380V series)	0
E3-08	Motor 2 V/F Freq. 2	0.1~600.0 Hz	0.0
E3-09	Motor 2 V/F Voltage 2	0.0~255.0V (220V series) 0.0~510.0V (380V series)	0
E3-10	Motor 2 Output Voltage Limit	0:Disable 1:Enable	0
E3-11	Motor 2 VF Pattern	0:Linear 1:Energy-saving 2:Square Curve 3:1.7 th power Curve 4:1.5 th power Curve	0
E3-12	Motor 2 Non-linear Start Freq.	0.1~600.0 Hz	0.0

Func.	Name	Range	dF60
E3-13	Motor 2 Non-Linear Start Voltage	0.0~255.0V (220V series) 0.0~510.0V (380V series)	0.0
E3-14	Voltage Boost Ratio at Accel.	0~100	0
E3-15	Voltage Buck Time after Boost Voltage	1.0~60.0 msec	10.0
E4-01	Motor 2 Rated Current	10~150% of drive rated current	—
E4-02	Motor 2 Rated Slip	0.00~20.00Hz	—
E4-03	Motor 2 No-Load Current	0~E4-01	—
E4-04	Motor 2 Motor Poles	1~24	4
E4-05	Motor 2 Line-to-Line Resistance	0.001~65.000Ω	—
E4-06	Motor 2 Leakage Inductance	0.01~40.0%	—
E4-07	Motor 2 Iron-Core Saturation Coefficient 1	0.01~1.00	0.9
E4-08	Motor 2 Iron-Core Saturation Coefficient 2	0.01~1.00	0.8
E4-09	Motor 2 Iron-Core Saturation Coefficient 3	0.01~1.00	0.7
E4-11	PM Motor 2 Ld	0.001~60.000mH	3.000
E4-12	PM Motor 2 Lq	0.001~60.000mH	3.000
E4-13	PM Motor 2 Back-EMF Constant	0.0~6500.0	60.0
F1-04	Overspeed (oS) Selection	0: Disable 2: Ramp to stop 1: Warn 3: Coast to stop	3
F1-05	oS Detection Level	0~120%	115
F1-06	oS Detection Time	0.0~2.0 sec	1.0
F1-07	Excessive Speed Deviation(dEv) Selection	0: Disable 2: Ramp to stop 1: Warn 3: Coast to stop	3
F1-08	dEv Detection Level	0~50 %	10
F1-09	dEv Detection Time	0.0~10.0 sec	1.0
H1-00	Multi-function Input Terminal (X1)	0:Disable ±1:Jog command ±2:FWD command ±3:REV command ±4:Start command ±5:Direction selection ±6:Stop command ±7:Secondary freq. command ±8:Secondary Accel./Decel. ±9:Multi-speed level 1 ±10:Multi-speed level 2 ±11:Multi-speed level 3 ±12:Multi-speed level 4 ±13:Accel./Decel. level 1 ±14:Accel./Decel. level 2 ±15:Multi-speed level 1 and Accel./Decel. level 1 ±16:Multi-speed level 2 and Accel./Decel. level 2	2
H1-01	Multi-function Input Terminal (X2)	±17:Reset command ±18:UP command ±19:DOWN command ±20:Set UP/DOWN freq.	3
H1-02	Multi-function Input Terminal (X3)		1

Func.	Name	Range	dF60
H1-03	Multi-function Input Terminal (X4)	±21:Clear UP/DOWN freq. ±22:External fault (EF) ±23: Interruption of output(bb) ±24: Coast to stop(Fr) ±25:Holding command ±26:Speed trace from the maximum freq. ±27:Speed trace from the setting freq. ±28:sequential operation Start ±29:Pause command of sequential operation ±30:Holding command of sequential operation ±31:DC braking enable at stop ±32:Current limit enable ±33:Secondary start command ±34:Secondary direction command ±35:Secondary freq.⊕ Secondary start⊕ Secondary direction	22
H1-04	Multi-function Input Terminal (X5)	±36:PID integral reset ±37:PID integral hold ±38:PID enable ±39:Second PID parameter ±40:PID softer start cancel ±41:Fast stop command ±42:LOCAL/ REMOTE select ±43:Field weakening ±44:Reserve ±45:Drive enable ±46:Forward/Reverse detection(V/F control with simple PG feedback) ±47:External overheat(OH3) ±48:Motor 2 select ±49:Offset freq. 0 ±50:Offset freq. 1 ±51:Offset freq. 2 ±52:Counter input ±53:Counter clear ±54:Timer input ±55:Speed/torque control select ±56:External fault 1(EF1) ±57:Reserve ±58:ASR gain select ±59:ASR integral reset ±60:Traverse function cancel ±61:Analog input selection ±62:PID enable ±63:Water tank full protection ±64:Fire mode	17
H1-05	Multi-function Input Terminal (X6)		0
H1-06	Multi-function Input Terminal (X7)		0
H1-07	Multi-function Input Terminal (X8)		0
H1-08	Response Time (X1)	1-500 msec	10
H1-09	Response Time (X2)	1-500 msec	10
H1-10	Response Time (X3)	1-500 msec	10
H1-11	Response Time (X4)	1-500 msec	10
H1-12	Response Time (X5)	1-500 msec	10
H1-13	Response Time (X6)	1-500 msec	10
H1-14	Response Time (X7)	1-500 msec	10
H1-15	Response Time (X8)	1-500 msec	10
H2-00	Multi-function digital output terminal (Y1)	0:Disable ±1:Detection during operation ±2:Constant speed detection ±3:Zero speed detection ±4:Freq. detection ±5:Overload detection (OLO) ±6:Stall prevention detection ±7:Low voltage detection (LE) ±8:Braking detection	3

Func.	Name	Range	dF60
H2-01	Multi-function digital output terminal (Y2)	±10:Restart after error condition detection ±11:Error detection ±12:Sequential operation detection ±13:Step end at sequential operation ±14:Cycle end at sequential operation ±15:Sequential operation pause detection ±16:Sequential operation holding detection ±17:Counter value 1 detection ±18:Counter value 2 detection ±19:Counter overflow detection ±20:Timer output ±21:Detection during reverse ±22:NTC heat level detection (Ht) ±23:Fan operation detection ±24:Reserve ±25:PID feedback low detection ±26:PID feedback high detection ±27:PID sleep detection ±28:Analog input detection 1 : Warn level detection ±29:Analog input detection 1 : Fault level detection ±30:Analog input detection 2 : Warn level detection ±31:Analog input detection 2 : Fault level detection ±32:LOCAL/REMOTE mode ±33:Drive ready ±34:Drive enable detection ±35:Fast stop detection ±36:Output interruption detection ±37:Speed trace detection ±38:Freq. detection (+/-) ±39:Freq. loss ±40:Torque detection 1 ±41:Torque detection 2 ±42:Motor 2 selection ±43:Traverse function detection ±44:Traverse function accel. detection ±45:Regeneration detection ±46:Torque limit detection ±47:Torque control speed limit detection	2
H2-04	Multi-function digital output terminal (Ta1,Tb1)		11
H2-05	Multi-function digital output terminal (Ta2,Tb2)		1
H3-01	Analog Input Selection (Vin)	0:Disable 1:Freq. (before gain) 2:Freq. gain 3:Freq. bias(after gain) 4:Auxiliary freq. 1 5:Auxiliary freq. 2 6:Current limit 7:PID setpoint 8:PID feedback 9:Differential PID feedback 10:Output voltage adjustment of V/F pattern 11:Analog input protection 1 12:Analog input protection 2 13:Freq. limit 14:Forward torque limit 15:Reverse torque limit 16:Regeneration torque limit 17:Torque limit / Torque command 18:Torque compensation 19:Torque limit	
H3-02	Gain (Vin)	-10.000-10.000	1.000
H3-03	Bias (Vin)	-10.000-10.000	0.00
H3-04	Input Range Selection (Vin)	0:0-10 Vdc 1:-10-10 Vdc	0

Func.	Name	Range	dF60
H3-05	Response Time (Vin)	0.000~50.000 sec	0.000
H3-11	Analog Input Selection (lin)	Please refer to H3-01	0
H3-12	Gain (lin)	-10.000~10.000	1.000
H3-13	Bias (lin)	-10.000~10.000	0.00
H3-14	Input Range Selection (lin)	0:0~10 Vdc 1:-10~10 mA	0
H3-15	Response Time (lin)	0.000~50.000 sec	0.000
H3-16	Offset (Vin)	-1.000~1.000	0
H3-18	Offset (lin)	-1.000~1.000	0
H3-20	Analog Input Selection (Virtual Analog Input 1)	Please refer to H3-01	0
H3-21	Virtual Analog Input 1 Value	-1.000~1.000	0.000
H3-24	Analog Input Selection	0~12	0
H4-00	Analog Output Selection (FM+)	0: None 1: Output freq. 2: Output freq. with compensation 3: Freq. command 4: Output voltage 5: Output current 6: PN voltage(DC Bus) 7: Vin input signal 9: lin input signal 10: KP Pot input signal 12: PID Set Point 13: PID Feedback 14: PID Differential Feedback 15: PID Adjusted Feedback 16: PID Input 17: PID Output 18: PID Output2 19: Drive temperature 20: External Temperature 22: Feedback freq.(PG) 21: Torque command	1
H4-01	Gain (FM+)	0~2.000	1.000
H4-02	Bias (FM+)	-1.000~1.000	0.000
H4-03	Analog Output Selection (AM+)	Refer to H4-00	5
H4-04	Gain (AM+)	0~2.000	1.000
H4-05	Bias (AM+)	-1.000~1.000	0.000
H4-07	Level Selection (AM+)	0:0~10V 1:0~20mA 2:4~20mA	1
H5-00	Comm. Adress	0~254	0
H5-01	Comm. Baud Rate	1200 bps 19200 bps 2400 bps 38400 bps 4800 bps 57600 bps 9600 bps 76800 bps 14400 bps 115200 bps	9600
H5-02	Comm. Protocol	8, N, 1 8, E, 1 8, N, 2 8, O, 1	8N1
H5-03	Drive Transmit Delay Time	5~65 msec	10
H5-04	Comm. Overtime Disposal (Cot)	0:Warning;Ramp to stop 1:Warning;Coast to stop 2:Warning;Keep running	0
H5-05	Comm. Overtime (Cot)	0.0~100.0 sec	0
H5-06	Comm. protocol Selection	0:Modbus RTU 1:Modbus ASCII	0

Func.	Name	Range	dF60
H5-07	Parameters Modify Mode by Comm.	0:Store at EEPROM 1:Don't store at EEPROM	0
L1-00	Current Limit constant (OL2)	0~255	0
L1-01	Grounding Protection constant (GF)	0~4	1
L1-02	Motor Overload Protection (OL)	0:Disable 1:Standard motor 2:Drive dedicated motor (external fan cooling)	1
L1-03	Motor Overload Protection Time	0~10.0 min	5.0
L1-06	Overheating Warning Selection (Oht)	0: None 1: Keep running 2: Carrier reduction 3: Stop	2
L1-07	Overheating Warning Level (Oht)	45~105℃	70
L1-08	Drive Overheating Dead Band	0.1~10.0℃	3.0
L1-09	Fan Control Selection	0:Start the fan at power ON 1:Start the fan at running 2:Start the fan according to the setting of L1-10	1
L1-10	Temperature Level of Fan Activation	25~65℃	50
L1-11	Fan Off Delay Time	0.1~25.0 min	0.5
L1-12	System Overload Detection (OLO)	0:Disable 1:Enable	0
L1-13	System Overload Detection Mode	0:During constant speed 1:During operation	0
L1-14	Output Setting after System Overload	0:Keeps operation 1:Trips to protection	0
L1-15	System Overload Detection Level	30~200%	160
L1-16	System Overload Detection Time	0.1~300.0 sec	0.1
L1-17	Dynamic Braking Selection	0:Disable 1:Enable	1
L1-18	Dynamic Braking Active Level	350~410V (220V series) 700~820V (380V series)	380 760
L1-19	Brake Resistor Pulse Setting	10~90%	50
L1-20	Input Phase Loss Protection Selection	0:Disable 1:Enable	1
L1-21	Output Phase Loss Protection Selection	0:Disable 1:Enable	1
L1-22	Current Limit Level	0.1~2.00	2.00
L1-23	NTC Thermistor	0:Enable 1:Disable,start the fan at power on 2:Disable,Start the fan at running	0
L1-24	Warring Temperature of Braking Resistor	10~255℃	120

Func.	Name	Range	dF60
L1-25	Resistance of Braking Resistor	0.01~500.00Ω	400.00
L1-26	Rated power of Braking Resistor	0.1~1000.0kW	0.1
L1-27	Temperature of Braking Resistor At Rated Power	1~1000℃	170
L2-00	Operation Selection at Instant Power Failure	0: Drive cannot be restarted 1: Drive can be restarted 2: Ramp to stop 3: Restart if the power restore during ramp to stop 4: Ramp to stop with KEB (Enable when start command is on) 5: Ramp to stop with KEB and drive restart 6: Ramp to stop with KEB	0
L2-01	Voltage Level of Ramp to Stop by Power Failure	210.0~270.0V (220V series) 420.0~540.0V (380V series)	250.0 450.0
L2-02	Subtracted Freq. of Ramp to Stop by Power Failure	0.0~20.0 Hz	0.5
L2-03	Deceleration Time 1 of Ramp to Stop by Power Failure	0.0~3200.0 sec	25.0
L2-04	Deceleration Time 2 of Ramp to Stop by Power Failure	0.0~3200.0 sec	25.0
L2-05	Switching Freq. of Ramp to Stop by Power Failure	0.0~400.0 Hz	0.0
L2-06	KEB setpoint DC Voltage	150~250V (220V series) 300~500V (380V series)	250.0 450.0
L2-07	KEB PI Gain (Kp)	0.000~5.000	0.12
L2-08	KEB PI Integration (Ki)	0.00~50.00	1.00
L2-09	KEB PI Limit	0.0~120.0Hz	60.0
L2-10	LE detection time	0~250ms	5
L3-00	Stall Prevention Level at Acceleration	30~200%	170
L3-01	Stall Prevention Level at Constant Speed	30~200%	160
L3-02	Acceleration Time after Stall Prevention under Constant Speed	0.1~3200.0 sec	5.0
L3-03	Deceleration Time for Stall Prevention under Constant Speed	0.1~3200.0 sec	5.0
L3-04	Stall Prevention at Deceleration	0: Disable 1: Enable	1
L3-05	Stall Prevention Delay Time	0~5000 msec	100
L3-06	Overvoltage Suppression Selection	0: Disable 1: Enable 2: Enable at constant speed	0
L3-07	Overvoltage Suppression Active Level	1.05~2.00	1.10

Func.	Name	Range	dF60
L3-08	Overvoltage Suppression Frequency Limit	0.0~30.0 Hz	6.0
L3-09	Overvoltage Suppression P Gain	0.000~5.000	0.100
L3-10	Overvoltage Suppression I Gain	0.00~50.00	5.00
L3-11	Overvoltage Suppression AVR Gain	10~50	50
L4-00	Constant Speed Detection Range	0.0~20.0 Hz	2.0
L4-01	Freq. Detection Level	0.0~400.0 Hz	0.0
L4-02	Freq. Detection Range	0.0~20.0 Hz	2.0
L4-03	Freq. Detection Level (+/-)	-400.0~400.0 Hz	0.0
L4-04	Freq. Detection Range (+/-)	0.0~20.0 Hz	2.0
L4-05	Freq. Detection Selection	0: Disable at baseblock (bb) 1: Enable at baseblock(bb)	1
L4-06	Freq. Command Loss Detection Selection	0: None 1: Stop 2: Keep running according to the L4-07.	0
L4-07	Freq. Command at Freq. Command Loss	0.000~1.000	0.800
L4-10	Torque Detection Selection 1	0: Disable 1: Detect OL3 at constant speed (Alarm) 2: Detect OL3 at running (Alarm) 3: Detect OL3 at constant speed (Fault) 4: Detect OL3 at running (Fault) 5: Detect UL3 at constant speed (Alarm) 6: Detect UL3 at run. (Alarm) 7: Detect UL3 at constant speed. (Fault) 8: Detect UL3 at running. (Fault)	0
L4-11	Torque Detection Level 1	0.00~3.00	1.50
L4-12	Torque Detection Time 1	00.~300.0 sec	1.50
L4-13	Torque Detection Selection 2	0: Disable 1: Detect OL4 at constant speed.(Alarm) 2: Detect OL4 at running (Alarm) 3: Detect OL4 at constant speed (Fault) 4: Detect OL4 at running (Fault) 5: Detect UL4 at constant speed (Alarm) 6: Detect UL4 at running (Alarm) 7: Detect UL4 at constant speed (Fault) 8: Detect UL4 at running (Fault)	1
L4-14	Torque Detection Level 2	0.00~3.00	1.50
L4-15	Torque Detection Time 2	0.0~300.0 sec	0.1
L5-00	Fault Restart Selection	0: Restart immediately after the fault is reset 1: Restart after the setting time in L5-02 PS. Only for OC · OE · GF	0
L5-01	Auto-restart Times Setting	0~16	0
L5-02	Fault Reset Interval Time	0.5~600.0 sec	10.0
L5-03	Output Terminal Selection During Auto Restart Fault	0: No detection 1: Detection	0

Func.	Name	Range	dF60
L5-04	Fault Auto-Reset Selection	0:Disable 1:Enable PS:Only for LE1,HF1,HF2	0
L6-00	Analog Input Detection 1 Fault Level (A1 Err)	0.000~1.000	0.000
L6-01	Analog Input Detection 1 Warn Level (A1 Warn)	0.000~1.000	0.000
L6-02	Analog Input Detection 1 Warn Dead Band	0.000~1.000	0.000
L6-03	Analog Input Detection 1 Warn Mode	0: None, digital output only 1: Warn 2: Ramp to stop 3: Coast to stop	0
L6-04	Analog Input Detection 2 Fault Level (A2 Err)	0.000~1.000	0.000
L6-05	Analog Input Detection 2 Warn Level (A2 Warn)	0.000~1.000	0.000
L6-06	Analog Input Detection 2 Warn Dead Band	0.000~1.000	0.000
L6-07	Analog Input Detection 2 Warn Mode	0:None, digital output only 1:Warn 2:Ramp to stop 3:Coast to stop	0
L6-08	External fault 1 (EF1) Selection	0:None 1:Warn 2:Ramp to stop 3:Coast to stop 4:Coast to stop + DC braking	1
L6-09	External fault 1 (EF1) Detection	0:Detection all the time 1:Detect during operation	1
L7-00	Forward Torque Limit	0.00~3.00	2.00
L7-01	Reverse Torque Limit	0.00~3.00	2.00
L7-02	Forward Regeneration Torque Limit	0.00~3.00	2.00
L7-03	Reverse Regeneration Torque Limit	0.00~3.00	2.00
P1-00	Sequence Control Mode	0:Direct Change 1:Stop before Change	0
P1-01	Sequence Control Direction	0:Single direction 1:Dual direction	0
P1-02	Sequence Control Cycle	1~9998:Number of cycle time 9999:Infinite cycles	1
P1-03	Accel/Decel Time Unit for Sequential Control	0:second 1:minute 2:hour	0
P1-04	Hold Time Unit for Sequential Control		0
P1-05	Accel/Decel Time of Sector 0	0.0~360.0	0.0
P1-06	Hold Time of Sector 0	0.0~360.0	0.0
P1-07	Accel/Decel Time of Sector 1	0.0~360.0	0.0
P1-08	Hold Time of Sector 1	0.0~360.0	0.0
P1-09	Accel/Decel Time of Sector 2	0.0~360.0	0.0

Func.	Name	Range	dF60
P1-10	Hold Time of Sector 2	0.0~360.0	0.0
P1-11	Accel/Decel Time of Sector 3	0.0~360.0	0.0
P1-12	Hold Time of Sector 3	0.0~360.0	0.0
P1-13	Accel/Decel Time of Sector 4	0.0~360.0	0.0
P1-14	Hold Time of Sector 4	0.0~360.0	0.0
P1-15	Accel/Decel Time of Sector 5	0.0~360.0	0.0
P1-16	Hold Time of Sector 5	0.0~360.0	0.0
P1-17	Accel/Decel Time of Sector 6	0.0~360.0	0.0
P1-18	Hold Time of Sector 6	0.0~360.0	0.0
P1-19	Accel/Decel Time of Sector 7	0.0~360.0	0.0
P1-20	Hold Time of Sector 7	0.0~360.0	0.0
P1-21	Accel/Decel Time of Sector 8	0.0~360.0	0.0
P1-22	Hold Time of Sector 8	0.0~360.0	0.0
P1-23	Accel/Decel Time of Sector 9	0.0~360.0	0.0
P1-24	Hold Time of Sector 9	0.0~360.0	0.0
P1-25	Accel/Decel Time of Sector 10	0.0~360.0	0.0
P1-26	Hold Time of Sector 10	0.0~360.0	0.0
P1-27	Accel/Decel Time of Sector 11	0.0~360.0	0.0
P1-28	Hold Time of Sector 11	0.0~360.0	0.0
P1-29	Accel/Decel Time of Sector 12	0.0~360.0	0.0
P1-30	Hold Time of Sector 12	0.0~360.0	0.0
P1-31	Accel/Decel Time of Sector 13	0.0~360.0	0.0
P1-32	Hold Time of Sector 13	0.0~360.0	0.0
P1-33	Accel/Decel Time of Sector 14	0.0~360.0	0.0
P1-34	Hold Time of Sector 14	0.0~360.0	0.0
P1-35	Accel/Decel Time of Sector 15	0.0~360.0	0.0
P1-36	Hold Time of Sector 15	0.0~360.0	0.0
P1-37	Sequence Control Direction	0~FFFF	0000
P1-39	Sequence Control Pause Mode	0:Pause with stop command. 1:Pause without stop command.	0
P2-00	Traverse Mode	0:Disable 1:Enable during constant speed 2:Enable during operation	0

Func.	Name	Range	df60
P2-01	Traverse Amplitude	0.00~0.20	0.00
P2-02	Traverse Step	0.00~0.50%	0.000
P2-03	Traverse Step Time	0.000~0.500 sec	0.000
P2-04	Traverse Deceleration Time	0.0~120.0 sec	0.0
P2-05	Traverse Acceleration Time	0.0~120.0 sec	0.0
o1-00	Gain (D-Axis Current)	0.01~10.00	1.00
o1-01	Gain (Q-Axis Current)	0.01~10.00	1.00
o1-02	Gain (Flux)	0.01~5.00	1.00
o1-04	Proportional Gain (D-Axis Current)	0.000~60.000	0.700
o1-05	Integral Gain (D-Axis Current)	0.0000~60.000	150.0
o1-06	Proportional Gain (Q-Axis Current)	0.000~60.000	0.700
o1-07	Integral Gain (Q-Axis Current)	0.0~6000.0	150.0
o1-08	Proportional Gain (Flux)	0.000~60.000	2.000
o1-09	Integral Gain (Flux)	0.00~600.00	10.00
o1-10	AutoTuning Acceleration Time (Rotational)	0.0~30.0 sec	5.0
o1-11	Motor PWM Deadtime	0~400	90
o1-12	Motor PWM Deadtime Smooth Angle	0.0~20.0	6.0
o1-13	Motor Current Angle Offset	-30.0~30.0	1.5
o1-14	Motor Current Angle LPF Constant (Numerator)	1~5000	64
o1-15	Motor Current Angle LPF Constant (Denominator)	1~5000	8
o1-16	Aniti Windup	0:Disable 1:Enable	0
o1-17	Flux Weakening Low Pass Filter	0.0~6000.0	100.0

Monitor Parameter List

Func.	Name	Description
U1-00	Control Method	0:V/F Control 2:Vector Control 6:PM Control 1 (I/F+EMF) 7:PM Control 2 (HFI+EMF)
U1-01	Freq.Command	Display the freq. command (Hz)
U1-02	Output Freq.	Display the output freq. (Hz)
U1-03	Output Voltage	Display the output voltage (V)
U1-04	Output Current	Display the output current (A)
U1-05	DC bus Voltage	Display the DC bus Voltage (V)
U1-06	Drive Temperature	Display the temperature of drive (°C)
U1-07	Input Terminal Status	Please refer to note 1
U1-08	Output Terminal Status	Please refer to note 2
U1-09	Motor Speed	Display RPM of motor
U1-10	Power Factor	Display the power factor
U1-11	Power Factor Angle	Display the power factor angle
U1-12	Output Freq. with Compensation	Display the output freq. with compensation (Hz)
U1-13	Drive Status	Please refer to note 3
U1-14	Output Power	Display the output power.
U1-15	Torque Output	Display torque commands as a percentage during vector control.
U1-16	Freq. command	Display the freq. command as a percentage.
U1-17	Output Freq.	Display the output freq. as a percentage.
U1-18	Output Power	Display the output power as a percentage.
U1-19	Error Code	Display the current fault code.
U1-20	Warning Code	Display the current warning code.
U1-21	Torque Command	Display torque commands as a percentage.
U1-22	Torque Compensation	Display the torque compensation as a percentage.
U1-24	MPM 0 Command	Display the machine speed command 0.
U1-25	Monitor MPM 0	Display the output machine speed 0.
U1-26	MPM 1 Command	Display the machine speed command 1.
U1-27	Monitor MPM 1	Display the output machine speed 1.
U1-28	MPM 2 Command	Display the machine speed command 2.
U1-29	Monitor MPM 2	Display the output machine speed 2.
U1-30	Saliency Ratio of HFI	Display the Saliency Ratio of HFI
U1-31	PM Estimated Speed (Besides IF Mode)	Display the PM estimated speed expect IF mode.
U1-32	PM Estimated Speed (For IF Mode)	Display the PM estimated speed in IF mode.
U1-33	PM Estimated Back-EMF Constant	Display the estimated back-EMF constant.
U2-00	Fault Histroy Item	Display the fault history item set by A5-00
U2-01	Error Code	Display the error code of U2-00
U2-02	Freq.command	Display the freq. command at U2-00 (Hz)
U2-03	Output freq.	Display the output freq. at U2-00 (Hz)
U2-04	Opout Voltage	Display the output voltage at U2-00 (V)
U2-05	Output current	Display the output current at U2-00 (A)
U2-06	DC Bus Voltage	Display the DC bus voltage at U2-00 (V)
U2-07	Drive Temperature	Display the drive temperature at U2-00 (°C)
U2-08	Cumulative Operation Time	Display the cumulative operation time at U2-00 (hr)

Func.	Name	Description
U2-09	Operation Status	Display the operation status at U2-00
U2-10	Input Terminal Status	Display the input terminal at U2-00
U2-11	Output Terminal Status	Display the output terminal at U2-00
U2-13	Torque Command	Display the torque command at U2-00(%)
U2-14	Q-Axis Current	Display the Q-axis current at U2-00(%)
U2-15	D-Axis Current	Display the D-axis current at U2-00(%)
U3-00	Fault History 0	Display the latest fault code.
U3-01	Fault History 1	Display the second last fault code.
U3-02	Fault History 2	Display the third last fault code.
U3-03	Fault History 3	Display the fourth last fault code.
U3-04	Fault History 4	Display the fifth last fault code.
U3-05	Fault History 5	Display the sixth last fault code.
U3-06	Fault History 6	Display the seventh last fault code.
U3-07	Fault History 7	Display the eighth last fault code.
U3-08	Fault History 8	Display the ninth last fault code.
U3-09	Fault History 9	Display the tenth last fault code.
U4-00	Power On Time	Display the cumulative power on time(hr)
U4-01	Operation Time	Display the cumulative operation time(hr)
U4-02	Cooling Fan Operation Time	Display the cumulative operation time of the cooling fan (hr)
U4-03	Cooling Fan Maintenance	Display the cooling fan operation time as a percentage (%)
U4-07	Motor Overload Estimate (OL)	Shows the value of the motor overload detection accumulator (%)
U4-08	kWh Lower Digit	Display the output power usage. Take 12345678.9kWh for example: U4-08:678.9kWh
U4-09	kWh upper Digit	U4-09:12345MWh
U4-10	Freq. command from Comm.	Display the freq. command from the Modbus communication (Hz)
U4-12	Frequency Command Source	Display the freq. command source Display format: XY-nn X:Freq. Command 0=Local 1=Primary Freq. (b1-00) 2=Secondary Freq. (b1-01) Y-nn: Source 0-00=Keypad 1-00~1-15=multispeed(d1-00~d1-15) 2-00~2-15=analog input and multispeed 3-00=Modbus Communication
U4-13	Start Command Source	Display the start command source Display format: XY-nn X:Start command 0=Local 1=Primary start command (b1-02) 2=Primary start command (b1-03) Y:Source 0:Keypad 1:Multi-function 2:Communication nn:Start command limit status 00:No limit status 01:Start command on at power on 02:Start command on at local/remote switch 03:Start command on during LE1 or LE 04:Fast stop
U4-14	Feedback Freq.	Display the feedback freq.
U4-15	Freq.Command	Display the freq. command
U4-16	Input Level (Vin)	Display the input level of Vin terminal
U4-18	Input Level (Iin)	Display the input level of Iin terminal
U4-19	Input Level (Pot)	Display the input level of keypad pot
U4-23	UP/DOWN Freq.	Display the UP/DOWN freq. (Hz)
U4-25	Torque Command from Comm.	Display the torque command set by communication (%)
U4-26	Torque Compensation from Comm.	Display the torque compensation set by communication (%)

Func.	Name	Description
U5-01	PID Setpoint	Display the PID setpoint (%)
U5-02	PID Feedback	Display the feedback of PID (%)
U5-03	PID Differential Feedback	Display the PID differential feedback (%)
U5-04	PID Adjusted Feedback	Display the PID adjusted feedback. (%)
U5-05	PID Input	Display the PID input (%)
U5-06	PID Output	Display the PID output (%)
U5-07	PID Output 2	Display the PID output 2 (%)
U5-08	PID Cumulative Integral Value	Display the PID cumulative integral value (%)
U6-01	Motor q-Axis Current	Displays the output value for motor q-Axis current (%)
U6-02	Motor d-Axis Current	Displays the output value for motor d-Axis current (%)
U6-03	Output Voltage Command (Vq)	Output voltage command for the q-Axis (Vac)
U6-04	Output Voltage Command (Vd)	Output voltage command for the d-Axis (Vac)
U6-05	Offset Freq.	Display the offset freq. (%)
U6-06	Current of Pulse	Display the current of pulse (A)
U7-01	Sequence Control: Cycle	Display the current number of sequence control cycle
U7-02	Sequence Control: Step	Display the current section of sequence control
U7-03	Digital Input Counter Value	Display the value of digital input counter
U7-04	Analog Input Current Limit	Display the current limit from analog input (A)
U7-05	Fault Restart Count	Display the count value of the Fault restart
U8-00	Software Version	Display the version of software
U8-01	Software CRC Code	Display the CRC code of software
U8-02	Parameter List CRC Code	Display the CRC code of parameter list
U8-03	Parameter CRC Code	Display the CRC code of parameter
U8-04	Drive HP	Display the horse power of drive (Hp)
U8-05	Drive Rated Current	Display the rated current of drive. (A)

Note:

(1) Input Terminal Status (U1-07):

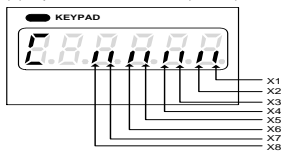

(2) Output Terminal Status (U1-08):

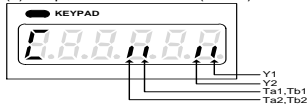

(3) Drive Status (U1-13):

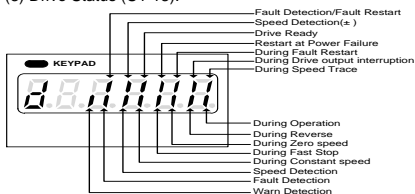

Error Trip Messages of Drive

Display	Description	Display	Description
	EEPROM Error		Keypad connection interrupted
	EEPROM Error 0		Drive overheat
	A/D converter error		Motor overheat
	Fuse open		Analog input protection 1
	Under voltage during operation		Analog input protection 2
	Drive over current		Input phase loss
	Grounding fault		Output phase loss
	Over voltage		NTC thermistor sensor fault
	PID feedback signal error		Operation command fault
	Start command lock 2 (Power ON/OFF)		Start command lock 3 (Local/Remote)
	External fault		External fault 1
	Motor Overload		Drive overload
	Current limit		Motor over torque 1
	System overload		Motor over torque 2
	Motor under torque 2		Motor under torque 1
	Speed deviation		Over speed

Warning Messages of Drive

Display	Description	Display	Description
	Power source under voltage		Keypad cable trip (before connecting)
	Drive output interruption		Keypad cable trip (connected)
	Coast to stop		Analog input warn 1
	Over voltage at stop		Analog input warn 2
	Parameter locked		Parameter Password Unlock
	Communication overtime		Direction command error
	Drive overheat		External overheat

■ Outline Dimension

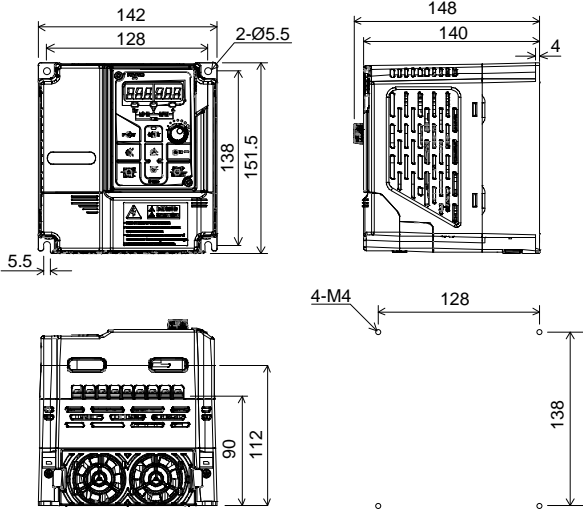

Unit:mm